

PBV (2317)

ISA-PLAN® PRECISION RESISTOR

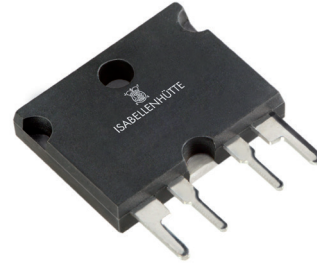

FEATURES

- Up to 10 W permanent power
- 4-terminal connection
- Pulse power rating 2 J for 10 ms
- Excellent long-term stability



APPLICATIONS

- Power modules
- Frequency converters
- Switch mode power supplies

Technical data

Resistance values	Ohm	0.0005 to 1
Tolerance	%	0.5 / 1 / 5
Temperature coefficient (20-60 °C)	ppm/K	<30 for $\geq 10\text{ m}\Omega$ <75 for $< 10\text{ m}\Omega$
Applicable temperature range	°C	-55 to +125
Power rating	W	3 / 10 (on a heatsink)
Thermal resistance to ambient (R_{th})	K/W	<15
Thermal resistance to aluminium substrat (R_{thi})	K/W	<3 <6 for parts <R002
Dielectric withstanding voltage	V AC	500
Inductance	nH	<10
Stability (at rated power) deviation after 2000h T_K = Terminal temperature	%	<0.5 ($T_K = 70\text{ °C}$)

Ordering code

PBV - R001 - F1 - 1.0

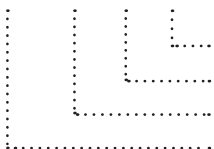

Tolerance
Terminal
Resistance value [Ohm] / „R“ represents decimal point
Type

Recommended solder profile

Reflow- and IR-soldering

Temperature	°C	260	255	217
Time	sec	peak	40	90

Packaging information

Specification	DIN EN 60286-3
Parts per tube	pcs 25

Assembly instruction

Max. allowed torque for screws M3	1 Nm
-----------------------------------	------

Mechanical dimensions [mm] and marking

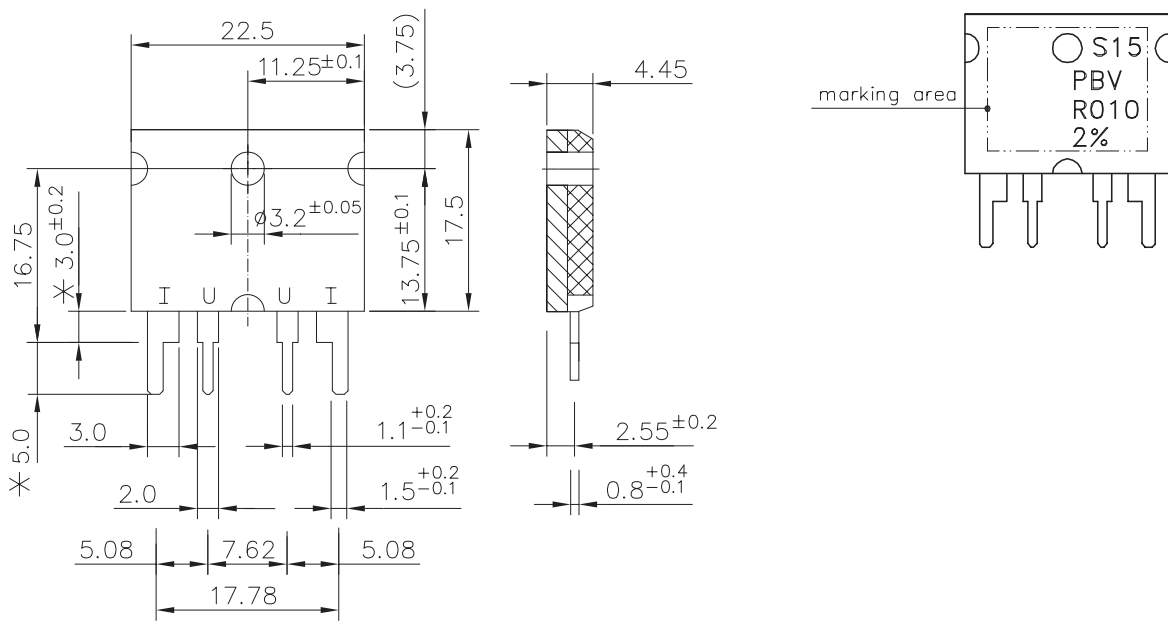

* Measurements for untinned pins

Z-DW-132b

Available standard resistance values and tolerances*

Resistance values	Tolerance		
	0.5	1.0	5.0
R0005		✓	
R0015	✓		
R001	✓	✓	✓
R002		✓	
R0022	✓	✓	
R003		✓	✓
R0033	✓	✓	
R0047	✓		
R005	✓	✓	
R0068	✓	✓	
R010	✓	✓	
R015	✓	✓	
R020	✓	✓	

Resistance values	Tolerance		
	0.5	1.0	5.0
R022	✓	✓	
R025	✓	✓	
R033	✓	✓	
R047	✓		
R050	✓	✓	
R068	✓		
R100	✓	✓	
R150	✓	✓	
R200	✓		
R220	✓	✓	
R500		✓	
1R00	✓		

✓ = available

* further values and tolerances on request

Temperature dependence of the electrical resistance of MANGANIN® resistors

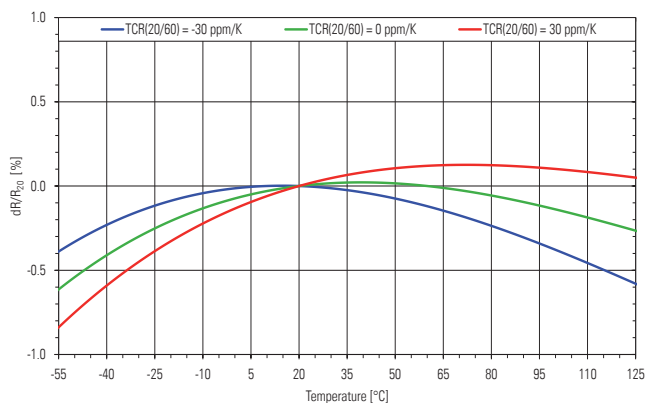

Temperature dependence of the electrical resistance of ZERANIN® resistors

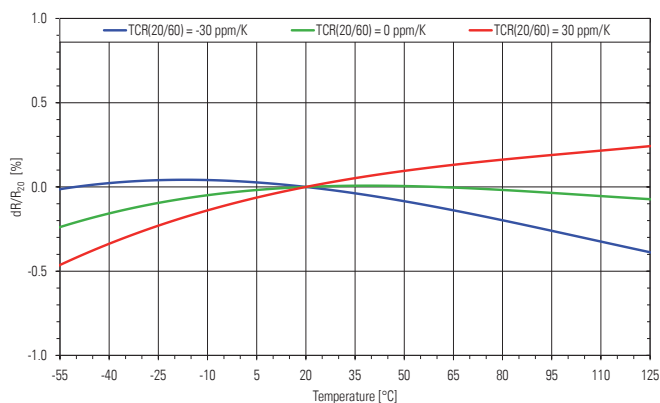

Power derating curve

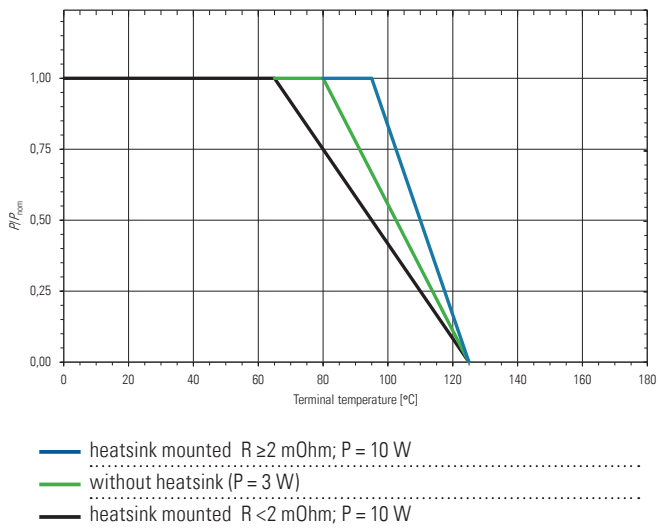

Maximum pulse energy respectively pulse power for permanent operation

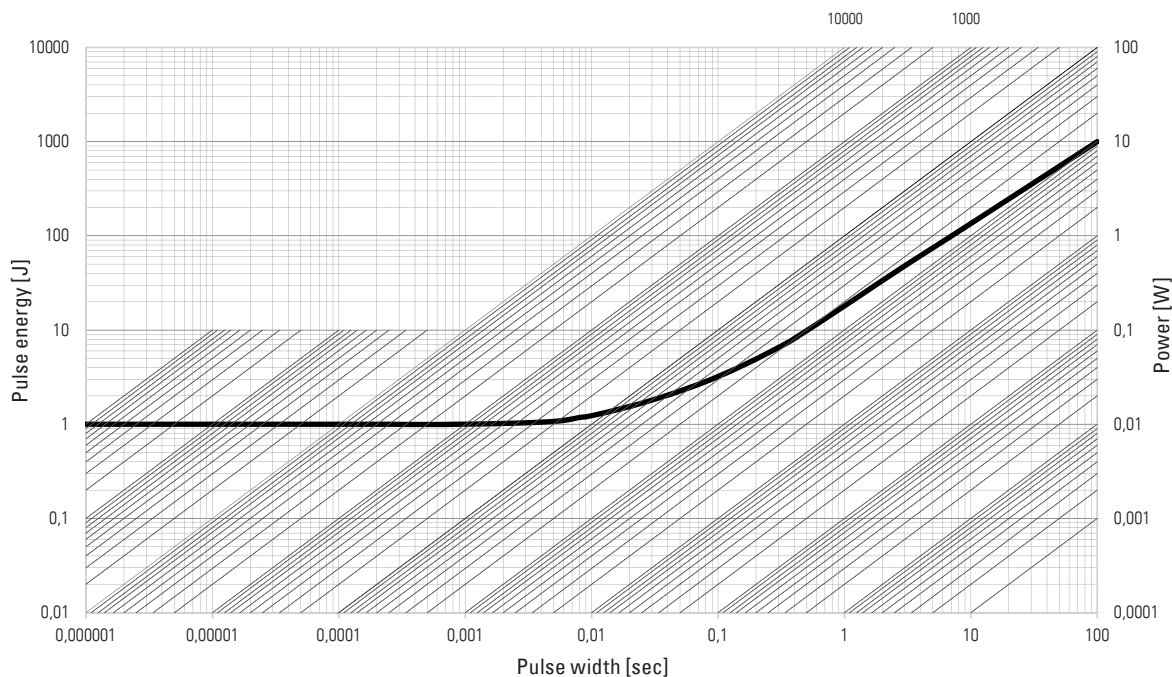

This curve is only valid for the resistance value R0005. The progression of the curve in the lower range could be different for other resistance values. Therefore a separate qualification should be made in thresholds.

Specification

Parameters	Test Conditions	Specification
Maximum Temperature for full power operation (R > 2 mOhm)	70/90 °C	65/95 °C
Working Temperature	-55 to 125 °C	-55 to 125 °C
Solderability	MIL-STD-202 method 208	> 95 % coverage
Resistance to Solvents	MIL-STD-202 method 215, 2.1a, 2.1d	no damage
Low Temperature Storage and Operation	MIL-STD-26E	0.1 %
Life	MIL-STD-26E	0.2 %
High Temperature Exposure	125 °C, 2000 h	0.2 %
Resistance Temperature Characteristic	MIL-STD-202 method 304 (20-60°C)	< 30 ppm/K
Thermal EMF	0 - 100 °C	2 µV/K max.
Frequency Characteristic	inductivity	< 10 nH

Disclaimer // All products, product specifications and data are subject to change without notice. The product specifications do not expand or otherwise modify Isabellenhütte's terms and conditions of sale, including but not limited to, the warranty expressed therein. Isabellenhütte makes no warranty, representation or guarantee other than as set forth in its terms and conditions of sale. Information provided in datasheets and/or specifications may vary from actual results in different applications. Any statements made by Isabellenhütte regarding the suitability of products for certain types of applications are based on its knowledge of typical requirements that are often placed on its products. It is the customer's responsibility to validate that a particular product with the properties described in the product specification is suitable for use in the application intended. No license, express or implied, or otherwise, to any intellectual property rights is granted by this document. Any and all liability arising out of the application or use of any product shall be as set forth in Isabellenhütte's terms and conditions of sale.

